

NOTES:

- 1 Refer to Secondary Sheet for Tabulated Data.
- 2 ϕ A1 and ϕ A2 shafts may near butt except:
 When any Bore $> \phi .375$ the component shaft MAX penetration is .255 or when both Bores $> \phi .375$ the component shaft MAX penetration is .255 & the MIN shaft end to shaft end is .490
- 3 Hubs and HELI-CAL FLEXURE are made from a single piece of material.
- 4 Set Screw attachment, hex socket, cup point set screw furnished: both hubs.
- 5 Backlash: None. No lubrication required.
- 6 Permitted axial motion from free length: $\pm .010$
- 7 RPM: Up to 10,000 depending upon application.
- 8 Torsional Flexibility: Refer to Tabulated Data.
- 9 Working torque ratings are based upon continuous duty with noted misalignments applied separately and may be increased with improved alignment: Refer to Tabulated Data.
- 10 Permissible shaft misalignment: Angular, up to 5°
Offset, up to .010 (FIM, .020)
- 11 Weight based on AR100-12-10

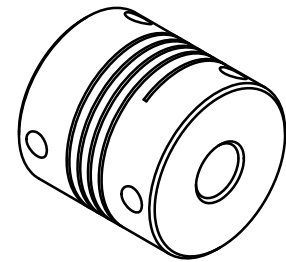
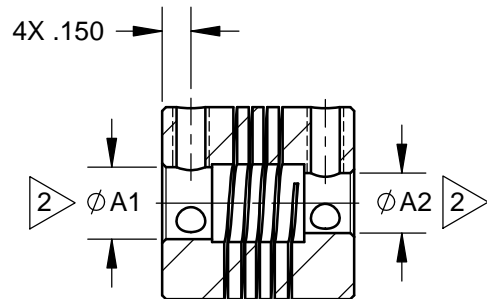
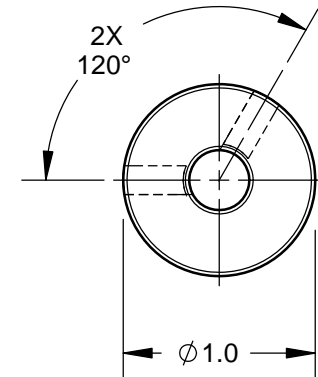
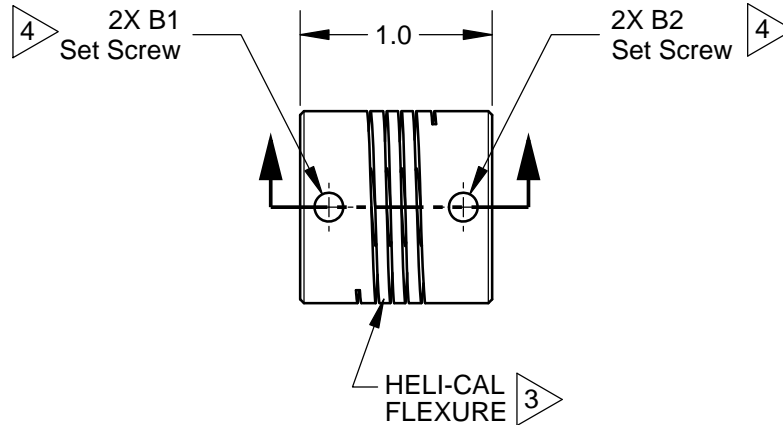

NOTICE: THE INFORMATION AND DATA CONTAINED HEREIN IS CONSIDERED PROPRIETARY TO HELICAL PRODUCTS COMPANY, INC., AND SHALL REMAIN THE EXCLUSIVE PROPERTY OF HELICAL. THE HOLDER WILL ASSUME CUSTODY AND CONTROL THAT THIS DOCUMENT WILL NOT BE COPIED, REPRODUCED OR DISCLOSED WITHOUT THE EXPRESS WRITTEN CONSENT OF HELICAL. POSSESSION OF THIS DOCUMENT DOES NOT CONSTITUTE A GRANT TO MANUFACTURE ANY ITEM. Copyright HELICAL PRODUCTS CO. INC.

11-26-14	---	ECR#14102000 Added calc. weight	DCE	EK
07-23-13	---	Redrawn in Solidworks	CL	JAJ/EK
12-18-09	---	Finish was Chromic Acid Anodize; Updated GD&T	HG	MC
04-08-92	---	Clerical format update/No Revision	BJM	MC
DATE	LTR	REVISION	APVR	

Unless otherwise specified all tolerances and dimensions are in inches.

Inch	Metric
X/XX \pm 1/64	X \pm 0.5mm
.XX \pm .01	X.X \pm 0.25mm
.XXX \pm .005	X.XX \pm 0.15mm

Angles $\pm 2^\circ$

Break sharp corners .010 MAX
All surface finish 63 roughness
Do Not Scale Drawing



HELICAL
PRODUCTS COMPANY, INC.

901 West McCoy Lane
P.O. BOX 1069
SANTA MARIA, CA. 93456 U.S.A.
PHONE (805) 928-3851 FSC13201

DRAWN BY MM	DATE 09-13-79	TITLE HELICAL FLEXIBLE SHAFT COUPLING
CHECKED BY MC	DATE 09-13-79	MATL 7075-T6 Aluminum Alloy
APPRVD BY APA	DATE 09-13-79	FINISH Anodize IAW HPS1000
WEIGHT (calculated) 27 g		DRAWING NUMBER AR100
SHEET 1 of 3		REV

TABULATED DATA

UOS all dimensions are in inches.
Copyright HELICAL PRODUCTS CO INC

MATERIAL: 7075-T6 Aluminum Alloy

FINISH: Anodize IAW HPS1000

Drawing Number

AR100

REV

DO NOT SCALE DRAWING

SHT 2 of 3

ITEM DESCRIPTION (Part Number)	BORE SIZES		SET SCREW		TORQUES (lbin)		
	∅A1	∅A2	B1	B2	Momentary	Non-Reversing	Shock or Reversing
AR100-6-4	.188in	.125in	#6-32	#4-40	36	18	9
AR100-6-6	.188in	.188in	#6-32	#6-32	36	18	9
AR100-8-3mm	.250in	3.00mm	#10-24	#4-40	36	18	9
AR100-8-4M	.250in	.120in	#10-24	#2-56	36	18	9
AR100-8-4	.250in	.125in	#10-24	#4-40	36	18	9
AR100-8-6	.250in	.188in	#10-24	#6-32	36	18	9
AR100-8-5mm	.250in	5.00mm	#10-24	#10-24	36	18	9
AR100-8-6mm	.250in	6.00mm	#10-24	#10-24	36	18	9
AR100-8-8	.250in	.250in	#10-24	#10-24	36	18	9
AR100-7mm-8	7.00mm	.250in	#10-24	#10-24	32	16	8
AR100-10-4	.313in	.125in	#10-24	#4-40	32	16	8
AR100-10-6	.313in	.188in	#10-24	#6-32	32	16	8
AR100-10-8	.313in	.250in	#10-24	#10-24	32	16	8
AR100-10-6.61mm	.313in	6.61mm	#10-24	#10-24	32	16	8
AR100-10-10	.313in	.313in	#10-24	#10-24	32	16	8
AR100-8mm-5mm	8.00mm	5.00mm	#10-24	#6-32	32	16	8
AR100-8mm-8	8.00mm	.250in	#10-24	#10-24	32	16	8
AR100-8mm-8mm	8.00mm	8.00mm	#10-24	#10-24	32	16	8
AR100-11-8	.344in	.250in	#10-24	#10-24	30	15	8
AR100-12-4M	.375in	.120in	#10-24	#2-56	28	14	7
AR100-12-4	.375in	.125in	#10-24	#4-40	28	14	7
AR100-12-5	.375in	.157in	#10-24	#6-32	28	14	7
AR100-12-6	.375in	.188in	#10-24	#6-32	28	14	7
AR100-12-5mm	.375in	5.00mm	#10-24	#6-32	28	14	7
AR100-12-6mm	.375in	6.00mm	#10-24	#10-24	28	14	7
AR100-12-8	.375in	.250in	#10-24	#10-24	28	14	7
AR100-12-7.5mm	.375in	7.50mm	#10-24	#10-24	28	14	7
AR100-12-10	.375in	.313in	#10-24	#10-24	28	14	7
AR100-12-8mm	.375in	8.00mm	#10-24	#10-24	28	14	7
AR100-12-11	.375in	.344in	#10-24	#10-24	28	14	7
AR100-12-12	.375in	.375in	#10-24	#10-24	28	14	7

TABULATED DATA

UOS all dimensions are in inches.
Copyright HELICAL PRODUCTS CO INC

MATERIAL: 7075-T6 Aluminum Alloy

FINISH: Anodize IAW HPS1000

Drawing Number

AR100

REV

DO NOT SCALE DRAWING

SHT 3 of 3

ITEM DESCRIPTION (Part Number)	BORE SIZES		SET SCREW		TORQUES (lbin)		
	∅A1	∅A2	B1	B2	Momentary	Non-Reversing	Shock or Reversing
AR100-9.91mm-10	9.91mm	.313in	#10-24	#10-24	28	14	7
AR100-10mm-6	10.00mm	.188in	#10-24	#6-32	28	14	7
AR100-10mm-8	10.00mm	.250in	#10-24	#10-24	28	14	7
AR100-10mm-12	10.00mm	.375in	#10-24	#10-24	28	14	7
AR100-10.7mm-6	10.70mm	.188in	#10-24	#6-32	28	14	7
AR100-14-14	.438in	.438in	#10-24	#10-24	28	14	7
AR100-12mm-8	12.00mm	.250in	#10-24	#10-24	28	14	7
AR100-12mm-12mm	12.00mm	12.00mm	#10-24	#10-24	28	14	7
AR100-12.58mm-6mm	12.58mm	6.00mm	#10-24	#10-24	28	14	7
AR100-16-4M	.500in	.120in	#10-24	#2-56	28	14	7
AR100-16-6	.500in	.188in	#10-24	#6-32	28	14	7
AR100-16-5.5mm	.500in	5.50mm	#10-24	#6-32	28	14	7
AR100-16-6mm	.500in	6.00mm	#10-24	#10-24	28	14	7
AR100-16-8	.500in	.250in	#10-24	#10-24	28	14	7
AR100-16-10	.500in	.313in	#10-24	#10-24	28	14	7
AR100-16-8mm	.500in	8.00mm	#10-24	#10-24	28	14	7
AR100-16-12	.500in	.375in	#10-24	#10-24	28	14	7
AR100-16-14	.500in	.438in	#10-24	#10-24	28	14	7
AR100-16-16	.500in	.500in	#10-24	#10-24	28	14	7
AR100-14mm-12	14.00mm	.375in	#10-24	#10-24	28	14	7
AR100-18-12	.563in	.375in	#10-24	#10-24	28	14	7
AR100-18-14	.563in	.438in	#10-24	#10-24	28	14	7
AR100-20-4M	.625in	.120in	#10-24	#2-56	28	14	7
AR100-20-4	.625in	.125in	#10-24	#4-40	28	14	7
AR100-20-8	.625in	.250in	#10-24	#10-24	28	14	7
AR100-20-12	.625in	.375in	#10-24	#10-24	28	14	7
AR100-16mm-8	16.00mm	.250in	#10-24	#10-24	28	14	7